

P1X Single zone touch panel



Technical Specs:

P1X: Dim Panel

- Input Voltage: AC85V-265V
- Output Signal: DMX512+2.4G Wireless
- DMX512 Socket: Wiring Terminal
- Dimming Range: 5%-100%
- Working Temperature: -20°C-55°C
- Dimension: L86×W86×H36(mm)
- Weight (G.W) : 230g

Receiver (R4-CC-2.4G)

- Working Voltage: DC12V-DC48V
- Output Current: 350/700mA×4CH
- Driving LEDs/CH: 1~12pcs 1W(3W) LED
- Receiver Distance: 30M
- Working Temp: -30°C-55°C
- Dimensions: L176×W46×H30(mm)
- Weight(N.W.): 137g

Installation:

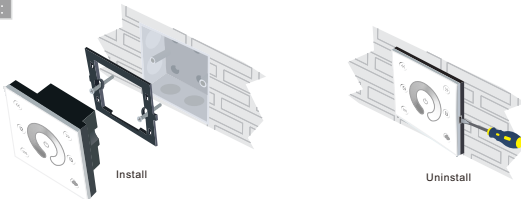

- 1 -

Wiring Diagram:

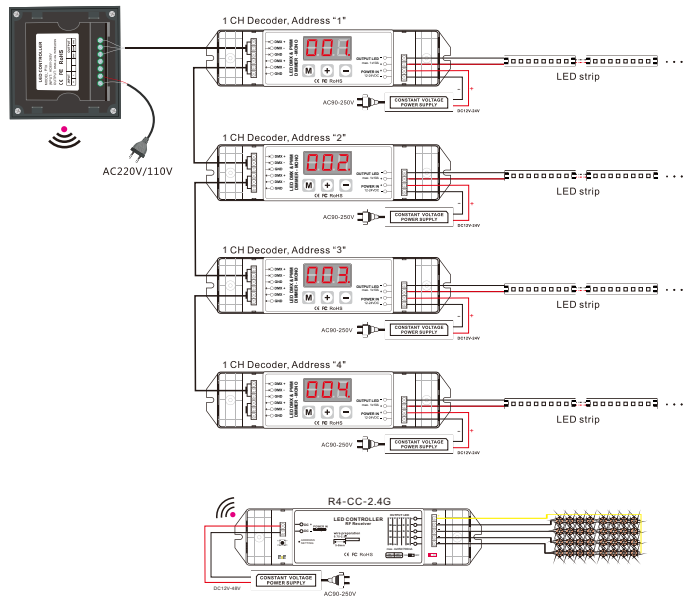

- 3 -

Key Functions:

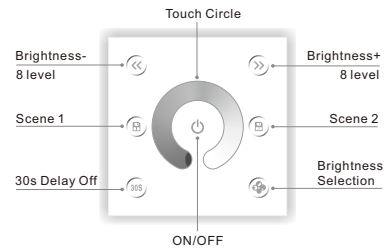

- ※ Long press to turn on/off the buzzer.
- ※ Short press to call scene, long press to save scene.
- ※ Hold the , keys for 2 second, the controller will restore default and restart automatically.

Receiver instruction:

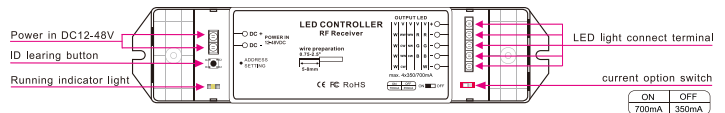

The matching method between panel and receiver :

learning ID: Press ID learning button on the receiver for 3 seconds. when the indicator light is on, press any zone key on the touch panel, the indicator light flashes (the frequency is 1Hz) , activated.
Cancel ID: Press ID learning button on the receiver for 5 seconds. When the indicator light flashed quickly (the frequency is 5Hz) , and all learnt IDs have been canceled.

Notice: The receiver can memorize up to 8 IDs. When receiving control information from any learnt ID, it can be controlled. If the memorized ID up to 8, long press learning key for 3 seconds to get out of the learning status, cancel the ID and reset.

- 2 -

After-Sales:

From the day you purchase our products within 3 years, if being used properly in accordance with the instruction, and quality problems occur, we provide free repair or replacement services except the following cases:

- 1.Any defects caused by wrong operations.
- 2.Any damages caused by inappropriate power supply or abnormal voltage.
- 3.Any damages caused by unauthorized removal, maintenance, modifying circuit, incorrect connections and replacing chips.
- 4.Any damages due to transportation, breaking, flooded water after the purchase.
- 5.Any damages caused by earthquake, fire, flood, lightning strike etc force majeure of natural disasters.
- 6.Any damages caused by negligence, inappropriate storing at high temperature and humidity environment or near harmful chemicals.
- 7.Product has been updated.

Kindly Reminder:

1.Power Source Selection

Power source must be DC constant voltage type of power supply. Due to the efficient output in some power supplies are only 80% of total, so please select at least 20% higher output power supply than the consumption of LED lights.

- 4 -